

APPLICATION NOTE

AN142

Audio circuits using the NE5532/3/4

author

1984 Oct

Audio circuits using the NE5532/3/4

AN142

AUDIO CIRCUITS USING THE NE5532/33/34

The following will explain some of Philips Semiconductors low noise op amps and show their use in some audio applications.

DESCRIPTION

The 5532 is a dual high-performance low noise operational amplifier. Compared to most of the standard operational amplifiers, such as the 1458, it shows better noise performance, improved output drive capability and considerably higher small-signal and power bandwidths.

This makes the device especially suitable for application in high quality and professional audio equipment, instrumentation and control circuits, and telephone channel amplifiers. The op amp is internally-compensated for gains equal to one. If very low noise is of prime importance, it is recommended that the 5532A version be used which has guaranteed noise voltage specifications.

APPLICATIONS

The Philips Semiconductors 5532 High-Performance Op Amp is an ideal amplifier for use in high quality and professional audio equipment which requires low noise and low distortion.

The circuit included in this application note has been assembled on a PC board, and tested with actual audio input devices (Tuner and Turntable). It consists of an RIAA (Recording Industry Association of America) preamp, input buffer, 5-band equalizer, and mixer. Although the circuit design is not new, its performance using the 5532 has been improved.

The RIAA preamp section is a standard compensation configuration with low frequency boost provided by the Magnetic cartridge and the RC network in the op amp feedback loop. Cartridge loading is accomplished via R1. 47k was chosen as a typical value, and may differ from cartridge to cartridge.

The Equalizer section consists of an input buffer, 5 active variable band pass/notch (depending on R9's setting) filters, and an output summing amplifier. The input buffer is a standard unity gain design providing impedance matching between the preamplifier and the equalizer section. Because the 5532 is internally-compensated, no external compensation is required. The 5-band active filter section is

actually five individual active filters with the same feedback design for all five. The main difference in all five stages is the values of C5 and C6, which are responsible for setting the center frequency of each stage. Linear pots are recommended for R9. To simplify use of this circuit, a component value table is provided, which lists center frequencies and their associated capacitor values. Notice that C5 equals (10) C6, and that the Value of R8 and R10 are related to R9 by a factor of 10 as well. The values listed in the table are common and easily found standard values.

RIAA EQUALIZATION AUDIO PREAMPLIFIER USING NE5532A

With the onset of new recording techniques with sophisticated playback equipment, a new breed of low noise operational amplifiers was developed to complement the state-of-the-art in audio reproduction. The first ultra-low noise op amp introduced by Philips Semiconductors was called the NE5534A. This is a single operational amplifier with less than 4nV/√Hz input noise voltage. The NE5534A is internally-compensated at a gain of three. This device has been used in many audio preamp and equalizer (active filter) applications since its introduction early last year.

Many of the amplifiers that are being designed today are DC-coupled. This means that very low frequencies (2-15Hz) are being amplified. These low frequencies are common to turntables because of rumble and tone arm resonances. Since the amplifiers can reproduce these sub-audible tones, they become quite objectionable because the speakers try to reproduce these tones. This causes non-linearities when the actual recorded material is amplified and converted to sound waves.

The RIAA has proposed a change in its standard playback response curve in order to alleviate some of the problems that were previously discussed. The changes occur primarily at the low frequency range with a slight modification to the high frequency range (See Figure 2). Note that the response peak for the bass section of the playback curve now occurs at 31.5Hz and begins to roll off below that frequency. The roll-off occurs by introducing a fourth RC network with a 7950μs time constant to the three existing networks that make up the equalization circuit. The high end of the equalization curve is extended to 20kHz, because recordings at these frequencies are achievable on many current discs.

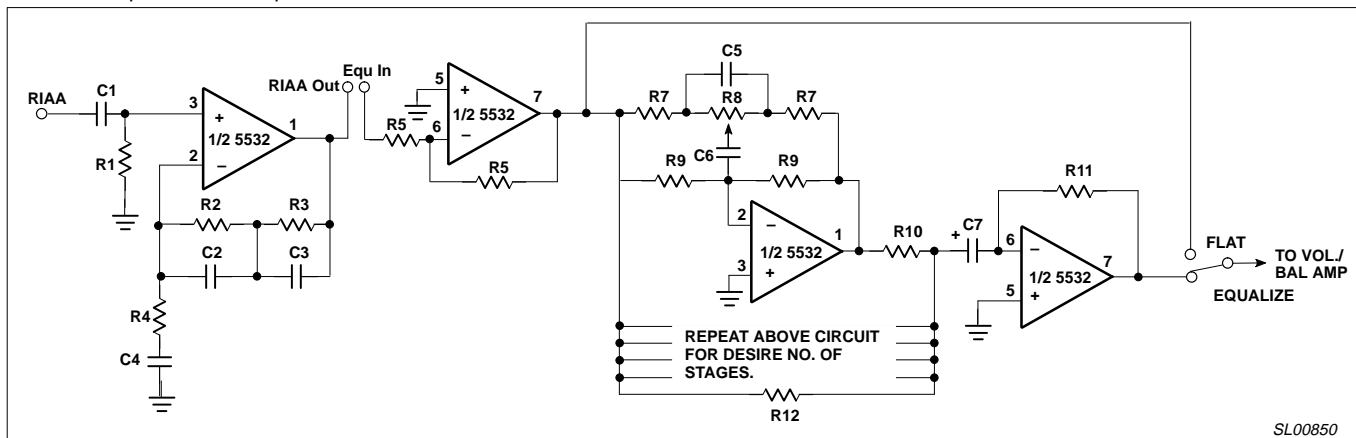

Figure 1. RIAA - Equalizer Schematic

SL00850

Audio circuits using the NE5532/3/4

AN142

COMPONENT VALUES FOR FIGURE 1

R8=25k R7=2.4k R9=240k			R8=50k R7=5.1k R9=510k			R8=100k R7=10k R9=1meg		
f _o	C5	C6	f _o	C5	C6	f _o	C5	C6
23Hz	1μF	0.1μF	25Hz	0.47μF	0.047μF	12Hz	0.47μF	0.047μF
50Hz	0.47μF	0.047μF	36Hz	0.33μF	0.033μF	18Hz	0.33μF	0.033μF
72Hz	0.33μF	0.033μF	54Hz	0.22μF	0.022μF	27Hz	0.22μF	0.022μF
108Hz	0.22μF	0.022μF	79Hz	0.15μF	0.015μF	39Hz	0.15μF	0.015μF
158Hz	0.15μF	0.015μF	119Hz	0.1μF	0.01μF	59Hz	0.1μF	0.01μF
238Hz	0.1μF	0.01μF	145Hz	0.082μF	0.0082μF	72Hz	0.082μF	0.0082μF
290Hz	0.082μF	0.0082μF	175Hz	0.068μF	0.0068μF	87Hz	0.068μF	0.0068μF
350Hz	0.068μF	0.0068μF	212Hz	0.056μF	0.0056μF	106Hz	0.056μF	0.0056μF
425Hz	0.056μF	0.0056μF	253Hz	0.047μF	0.0047μF	126Hz	0.047μF	0.0047μF
506Hz	0.047μF	0.0047μF	360Hz	0.033μF	0.0033μF	180Hz	0.033μF	0.0033μF
721Hz	0.033μF	0.0033μF	541Hz	0.022μF	0.0022μF	270Hz	0.022μF	0.0022μF
1082Hz	0.022μF	0.0022μF	794Hz	0.015μF	0.0015μF	397Hz	0.015μF	0.0015μF
1588Hz	0.015μF	0.0015μF	1191Hz	0.01μF	0.001μF	595Hz	0.01μF	0.001μF
2382Hz	0.01μF	0.001μF	1452Hz	0.0082μF	820pF	726Hz	0.0082μF	820pF
2904Hz	0.0082μF	820pF	1751Hz	0.0068μF	680pF	875Hz	0.0068μF	680pF
3502Hz	0.0068μF	680pF	2126Hz	0.0056μF	560pF	1063Hz	0.0056μF	560pF
4253Hz	0.0056μF	560pF	2534Hz	0.0047μF	470pF	1267Hz	0.0047μF	470pF
5068Hz	0.0047μF	470pF	3609Hz	0.0033μF	330pF	1804Hz	0.0033μF	330pF
7218Hz	0.0033μF	330pF	5413Hz	0.0022μF	220pF	2706Hz	0.0022μF	220pF
10827Hz	0.0022μF	220pF	7940Hz	0.0015μF	150pF	3970Hz	0.0015μF	150pF
15880Hz	0.0015μF	150pF	11910Hz	0.001μF	100pF	5955Hz	0.001μF	100pF
23820Hz	0.001μF	100pF	14524Hz	820pF	82pF	7262Hz	820pF	82pF
			17514Hz	680pF	68pF	8757Hz	680pF	68pF
			21267Hz	560pF	56pF	10633Hz	560pF	56pF
						12670Hz	470pF	47pF
						18045Hz	330pF	33pF

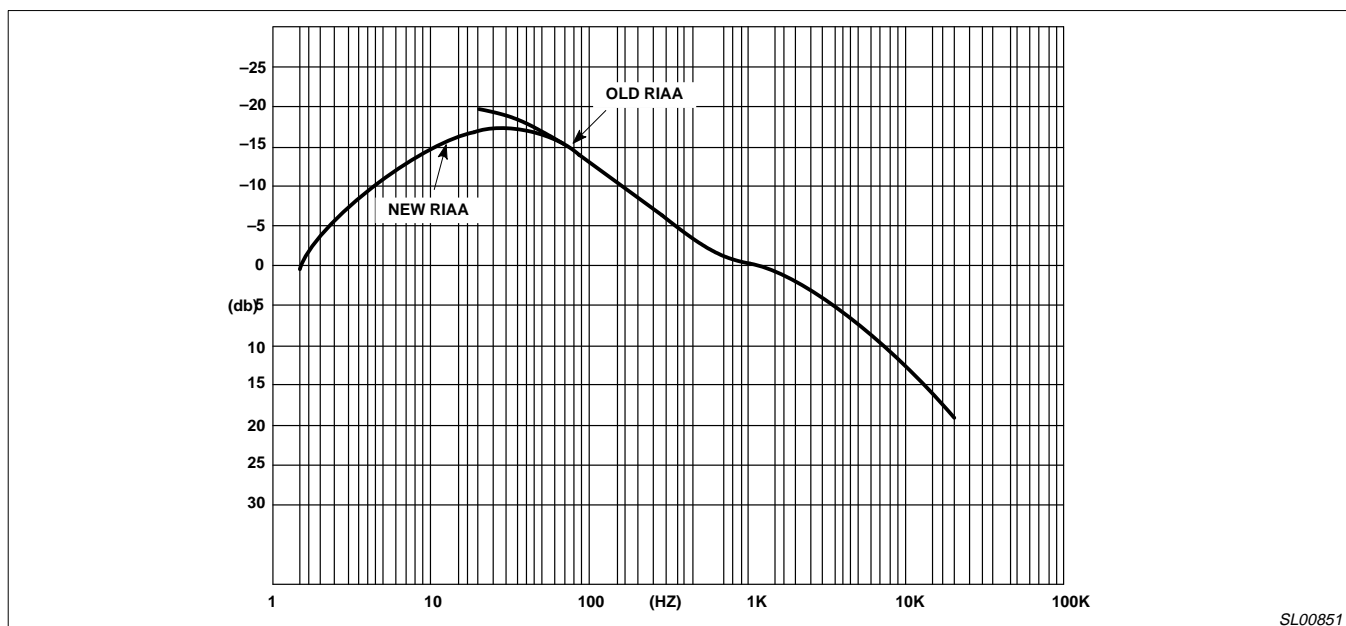

Figure 2. Proposed RIAA Playback Equalization

SL00851

Audio circuits using the NE5532/3/4

AN142

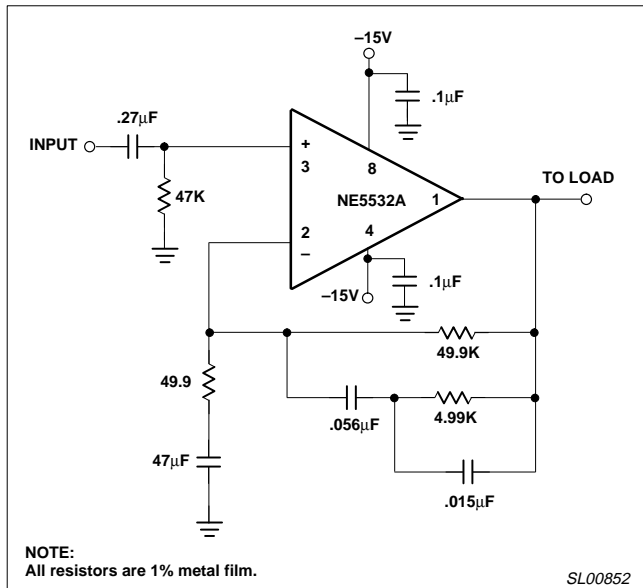

Figure 3. RIAA Phonograph Preamp Using the NE5532A

NE5533/34 DESCRIPTION

The 5533/5534 are dual and single high-performance low noise operational amplifiers. Compared to other operational amplifiers, such as TL083, they show better noise performance, improved output drive capability and considerably higher small-signal and power bandwidths.

This makes the devices especially suitable for application in high quality and professional audio equipment, instrumentation and control circuits, and telephone channel amplifiers.

The op amps are internally-compensated for gain equal to, or higher than, three. The frequency response can be optimized with an external compensation capacitor for various applications (unity gain amplifier, capacitive load, slew rate, low overshoot, etc.) If very low noise is of prime importance, it is recommended that the 5533A/5534A version be used which has guaranteed noise specifications.

APPLICATIONS

Diode Protection of Input

The input leads of the device are protected from differential transients above $\pm 0.6V$ by internal back-to-back diodes. Their presence imposes certain limitations on the amplifier dynamic characteristics related to closed-loop gain and slew rate.

Consider the unity gain follower as an example:

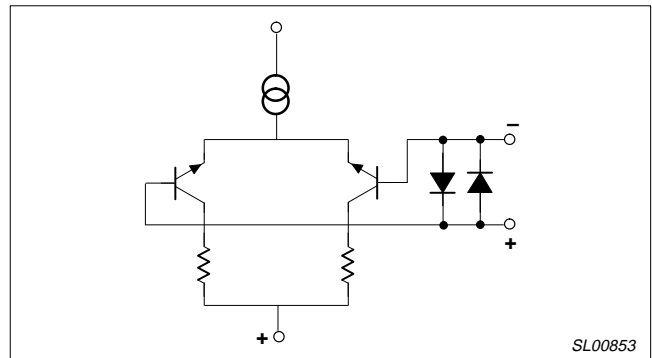

Figure 4.

Assume a signal input square wave with dV/dt of $250V/\mu s$ and $2V$ peak amplitude as shown. If a $22pF$ compensation capacitor is inserted and the $R_1 C_1$ circuit deleted, the device slew rate falls to approximately $7V/\mu s$. The input waveform will reach $2V/250V/\mu s$ or $8ns$, while the output will have changed (8×10^{-3}) only $56mV$. The differential input signal is then $(V_{IN} - V_O) R_I / (R_I + R_F)$ or approximately $1V$.

The diode limiter will definitely be active and output distortion will occur; therefore, $V_{IN} < 1V$ as indicated.

Next, a sine wave input is used with a similar circuit.

The slew rate of the input waveform now depends on frequency and the exact expression is

$$\frac{dv}{dt} = 2\omega \cos \omega t$$

The upper limit before slew rate distortion occurs for small-signal ($V_{IN} < 100mV$) conditions is found by setting the slew rate to $7V/\mu s$. That is:

$$7 \times 10^6 V/\mu s = 2\omega \cos \omega t$$

at $\omega t = 0$

$$\omega_{LIMIT} = \frac{7 \times 10^6}{2} = 3.5 \times 10^6 \text{ rad/s}$$

$$f_{LIMIT} = \frac{3.5 \times 10^6}{2\pi} \approx 560 \text{ kHz}$$

Audio circuits using the NE5532/3/4

AN142

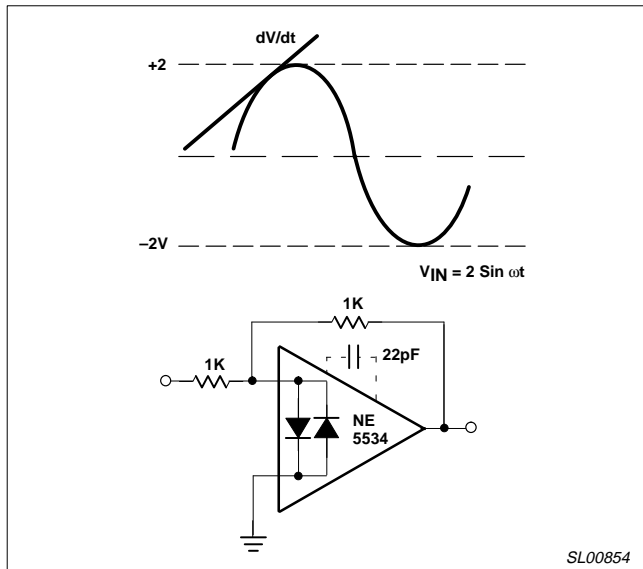

Figure 5.

External Compensation Network Improves Bandwidth

By using an external lead-lag network, the follower circuit slew rate and small-signal bandwidth can be increased. This may be useful in situations where a closed-loop gain less than 3 to 5 is indicated. A number of examples are shown in subsequent figures. The principle benefit of using the network approach is that the full slew rate and bandwidth of the device is retained, while impulse-related parameters such as damping and phase margin are controlled by choosing the appropriate circuit constants. For example, consider the following configuration:

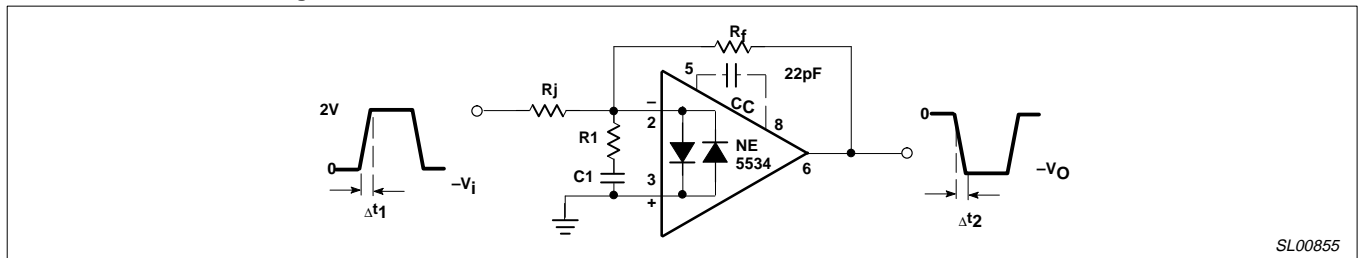

Figure 6.

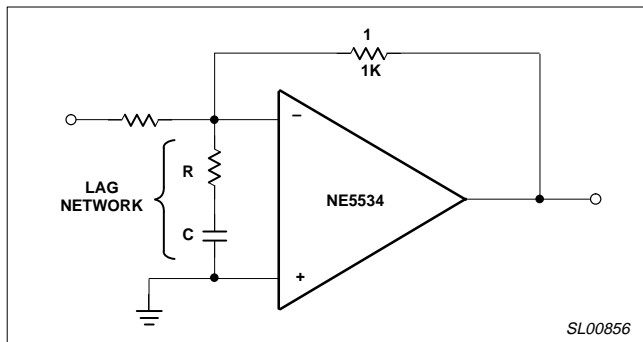

Figure 7.

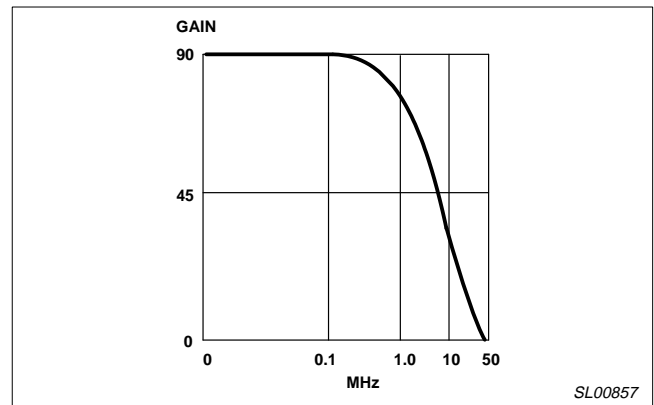

Figure 8.

Audio circuits using the NE5532/3/4

AN142

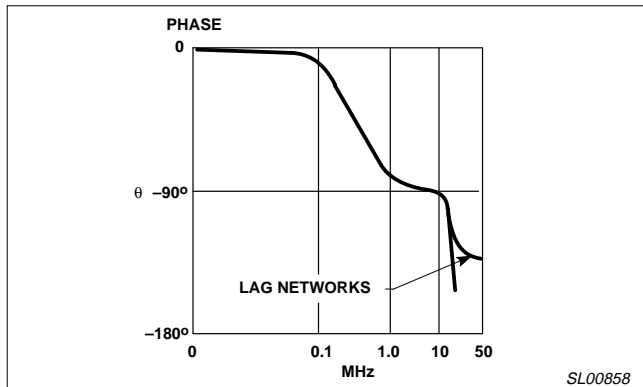

Figure 9.

The major problem to be overcome is poor phase margin leading to instability.

By choosing the lag network break frequency one decade below the unity gain crossover frequency (30-50MHz), the phase and gain margin are improved. An appropriate value for R is 270Ω. Setting the lag network break frequency at 5MHz, C may be calculated

$$C = \frac{1}{2\pi \cdot 270 \cdot 5 \times 10^6}$$

$$= 118\text{pF}$$

RULES AND EXAMPLES

Compensation Using Pins 5 and 8 (Limited Bandwidth and Slew Rate)

A single-pole and zero inserted in the transfer function will give an added 45° of phase margin, depending on the network values.

Calculating the Lead-Lag Network

$$C_1 = \frac{1}{2\pi F_1 R_1} \text{ Let } R_1 = \frac{R_{IN}}{10}$$

where

$$F_1 = \frac{1}{10} \text{ (UGBW)}$$

$$\text{UGBW} = 30\text{MHz}$$

External Compensation for Wide-Band Voltage-Follower

Shunt Capacitance Compensation

$$C_F = \frac{1}{2\pi F_F R_F}, F_F \approx 30\text{MHz}$$

or

$$C_F \approx \frac{C_{DIST}}{A_{CL}}$$

$C_{DIST} \approx$ Distributed Capacitance $\approx 2 - 3\text{pF}$

Many audio circuits involve carefully-tailored frequency responses. Pre-emphasis is used in all recording mediums to reduce noise and produce flat frequency response. The most often used de-emphasis curves for broadcast and home entertainment systems are shown in Figure 13. Operational amplifiers are well suited to these

applications because of their high gain and easily-tailored frequency response.

RIAA PREAMP USING THE NE5534

The preamplifier for phono equalization is shown in Figure 14 with the theoretical and actual circuit response.

Low frequency boost is provided by the inductance of the magnetic cartridge with the RC network providing the necessary break points to approximate the theoretical RIAA curve.

RUMBLE FILTER

Following the amplifier stage, rumble and scratch filters are often used to improve overall quality. Such a filter designed with op amps uses the 2-pole Butterworth approach and features switchable break points. With the circuit of Figure 15, any degree of filtering from fairly sharp to none at all is switch-selectable.

tone CONTROL

Tone control of audio systems involves altering the flat response in order to attain more low frequencies or more high ones, dependent upon listener preference. The circuit of Figure 16 provides 20dB of bass or treble boost or cut as set by the variable resistance. The actual response of the circuit is shown also.

BALANCE AND LOUDNESS AMPLIFIER

Figure 17 shows a combination of balance and loudness controls. Due to the non-linearity of the human hearing system, the low frequencies must be boosted at low listening levels. Balance, level, and loudness controls provide all the listening controls to produce the desired music response.

VOLTAGE AND CURRENT OFFSET ADJUSTMENTS

Many IC amplifiers include the necessary pin connections to provide external offset adjustments. Many times, however, it becomes necessary to select a device not possessing external adjustments. Figures 18, 19, and 20 suggest some possible arrangements for off-circuitry. The circuitry of Figure 20 provides sufficient current into the input to cancel the bias current requirement. Although more simplified arrangements are possible, the addition of Q2 and Q3 provide a fixed current level to Q1, thus, bias cancellation can be provided without regard to input voltage level.

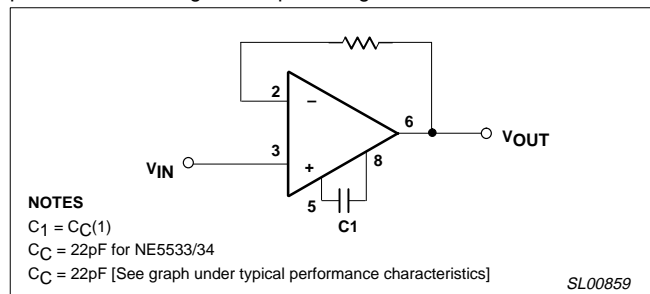

NOTES
 $C_1 = C_C(1)$
 $C_C = 22\text{pF}$ for NE5533/34
 $C_C = 22\text{pF}$ [See graph under typical performance characteristics]

SL00859

Figure 10. Unity Gain Non-Inverting Configuration

Audio circuits using the NE5532/3/4

AN142

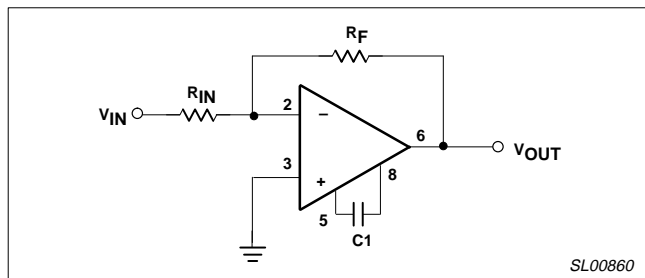

Figure 11. Unity Gain Inverting Configuration

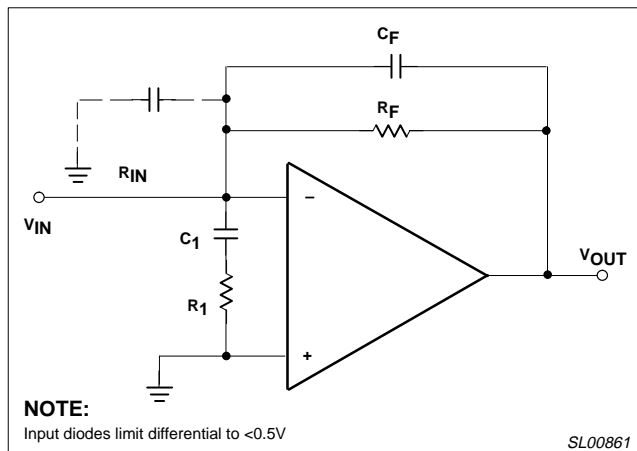
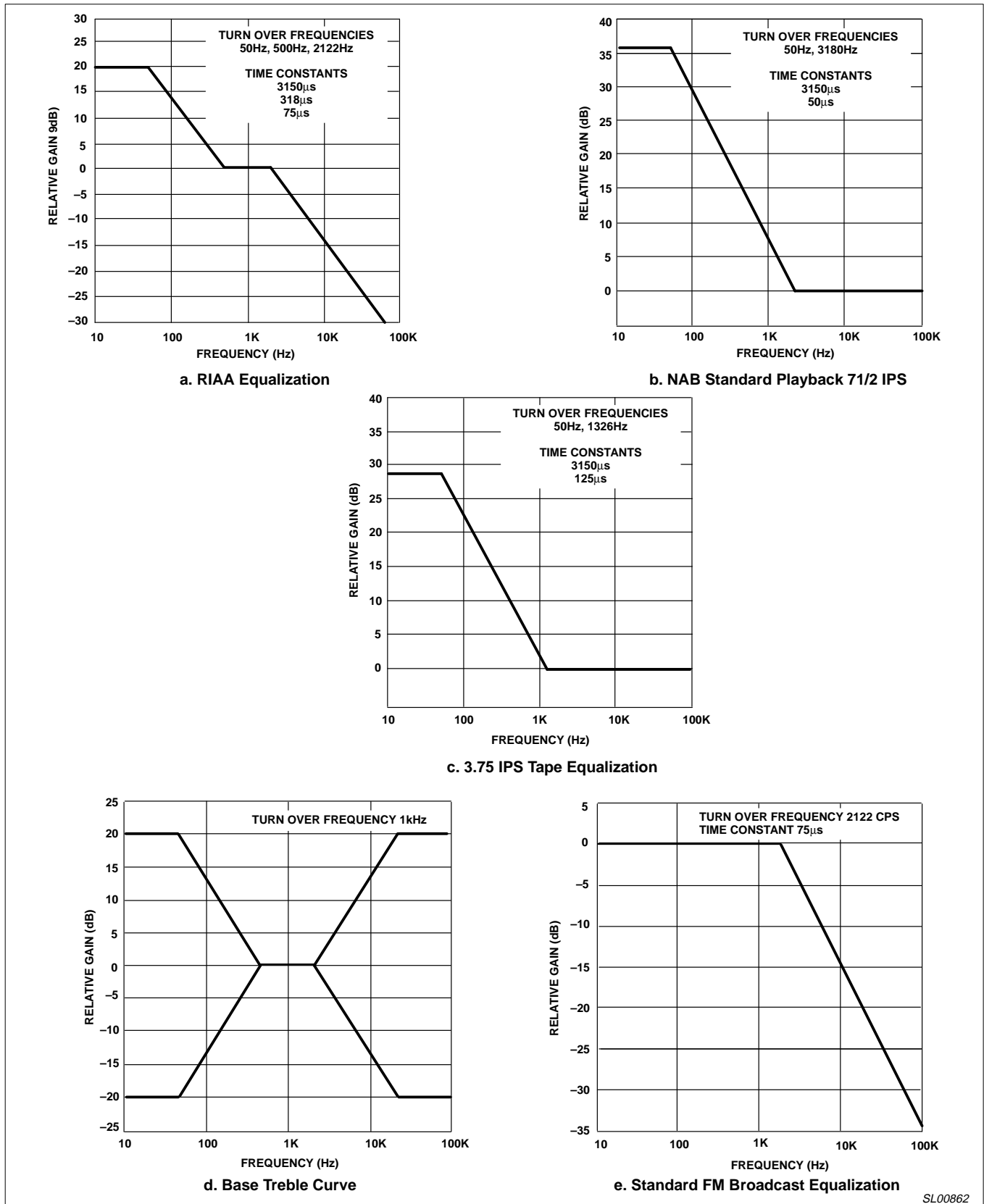

Figure 12. External Compensation for Wideband Voltage Follower

Audio circuits using the NE5532/3/4

AN142



SL00862

Figure 13.

Audio circuits using the NE5532/3/4

AN142

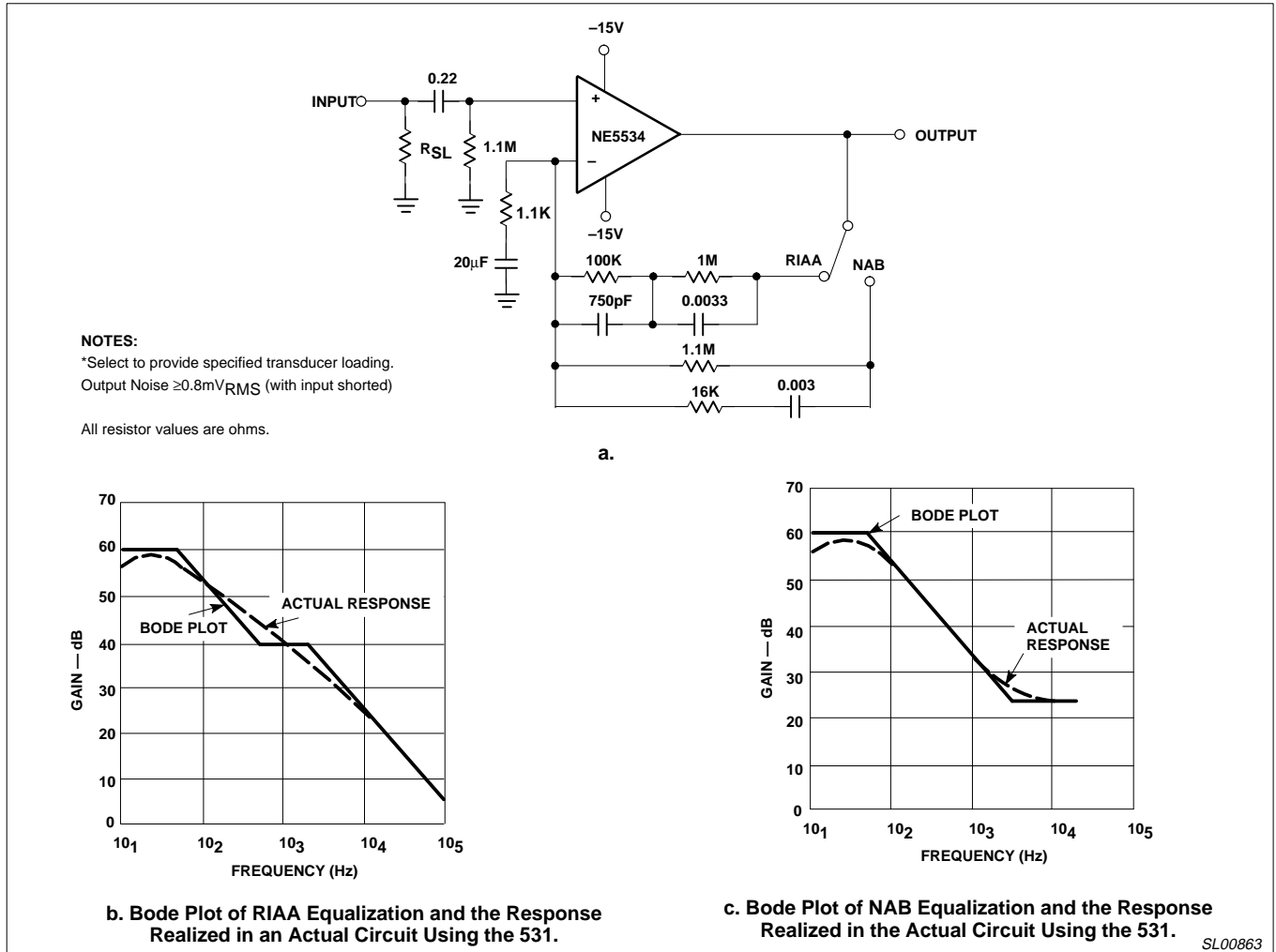

Figure 14. Preamplifier - RIAA/NAB Compensation

Audio circuits using the NE5532/3/4

AN142

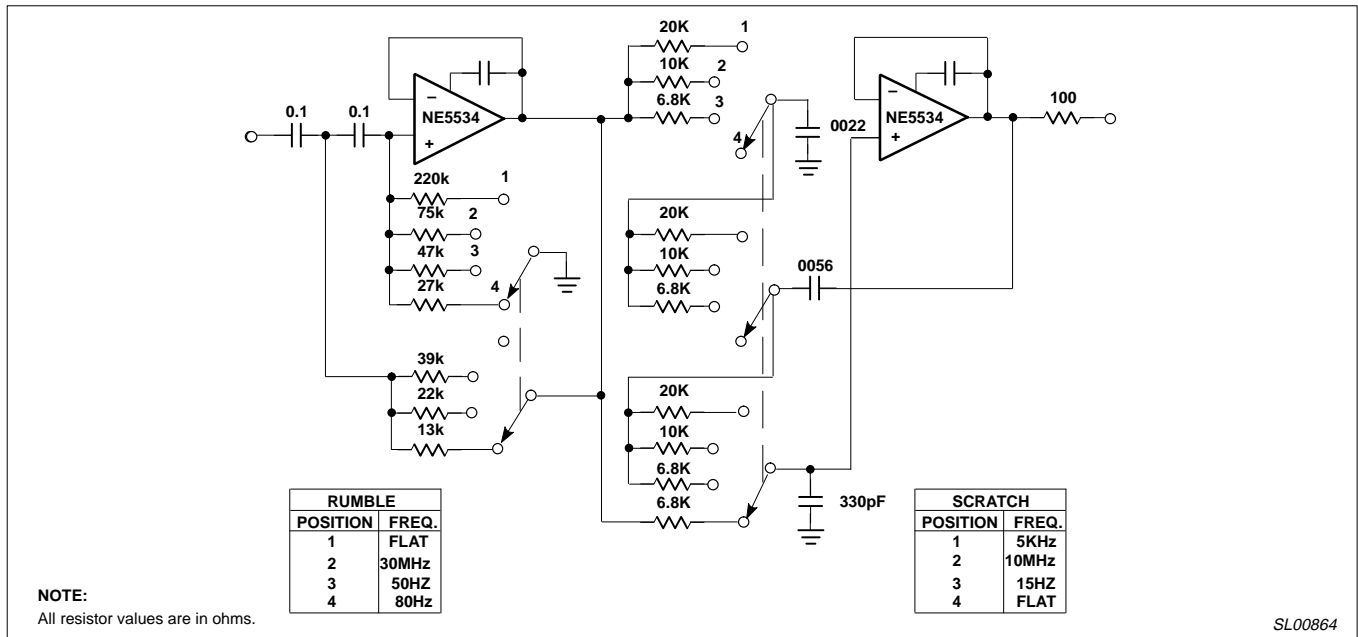

Figure 15. Rumble/Scratch Filter

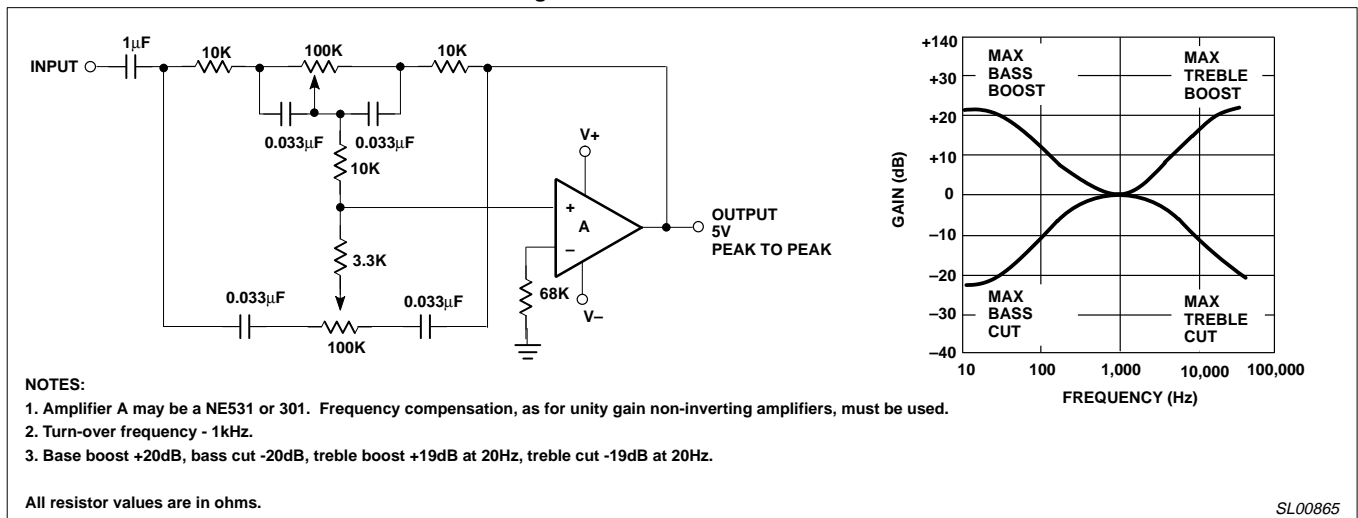

Figure 16. Tone Control Circuit for Operational Amplifiers

Audio circuits using the NE5532/3/4

AN142

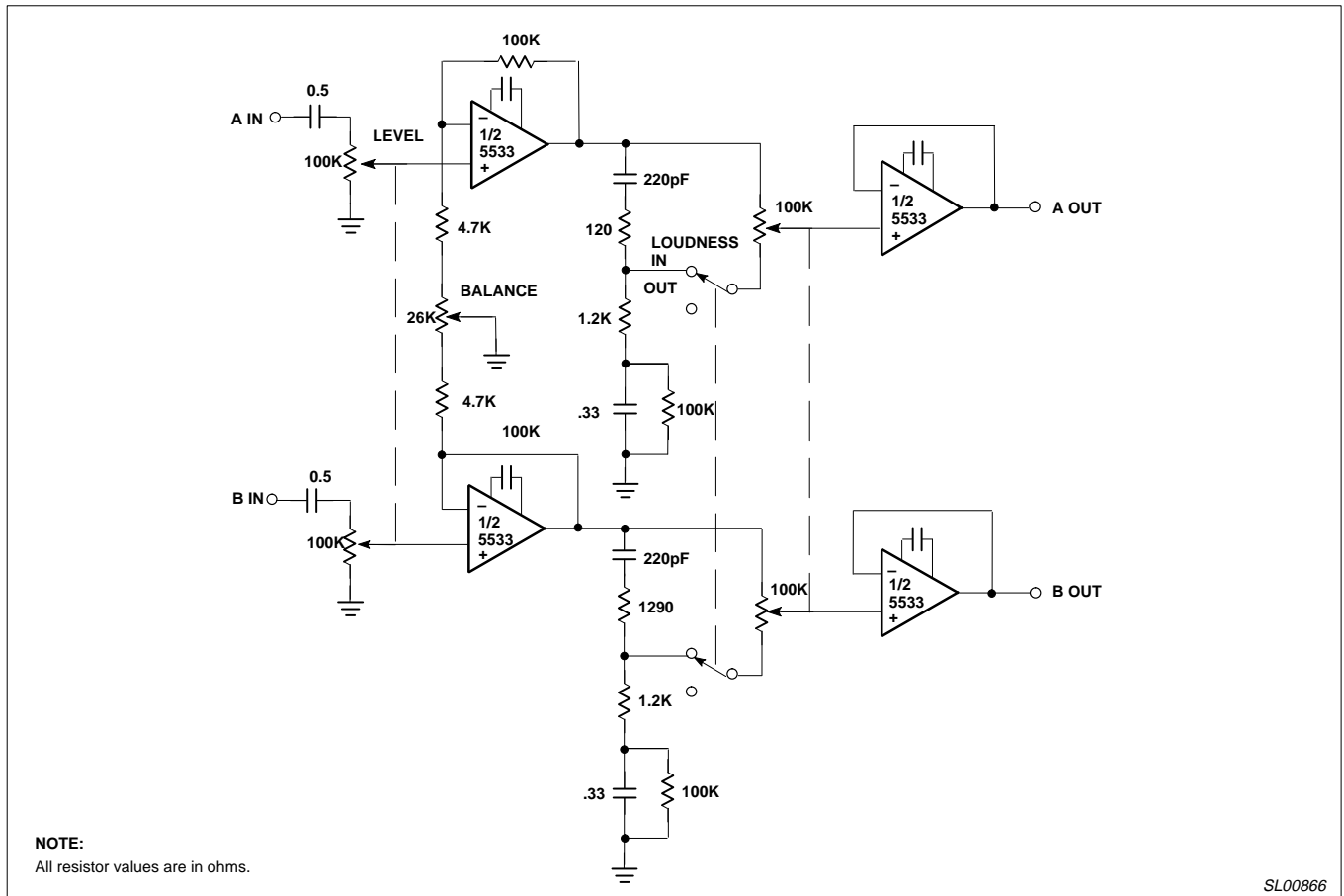

Figure 17. Balance Amplifier with Loudness Control

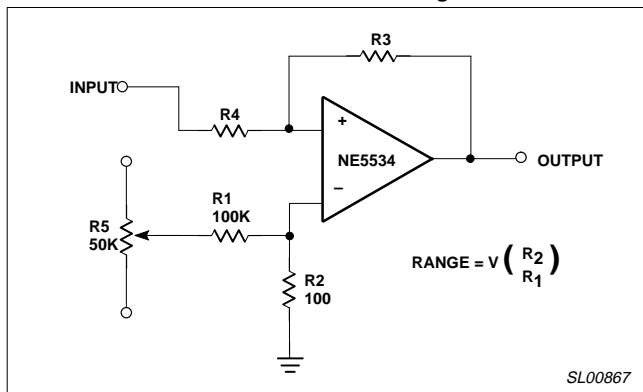

Figure 18. Universal Offset Null for Inverting Amplifiers

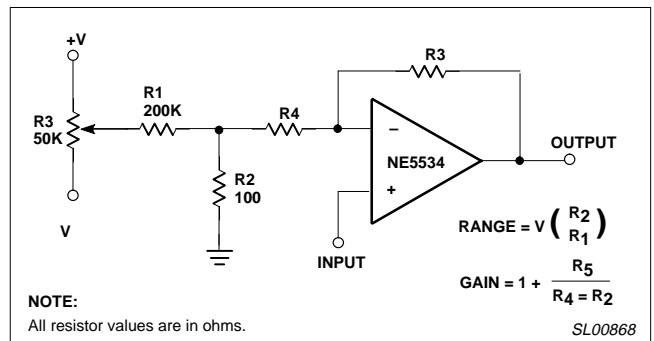

Figure 19. Universal Offset Null for Non-Inverting Amplifiers

Audio circuits using the NE5532/3/4

AN142

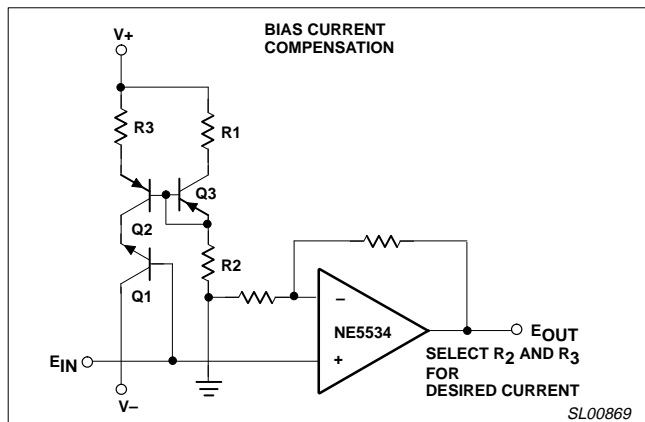

Figure 20. Bias Current Compensation