

A New Phase-Shifterless Beam-Scanning Technique Using Arrays of Coupled Oscillators

P. Liao, *Student Member, IEEE*, and R. A. York, *Member, IEEE*

Abstract—A method for electronic beam scanning in linear arrays of antenna-coupled oscillators is introduced which eliminates the need for phase shifters. It is shown that a constant phase progression can be established by slightly detuning the peripheral array elements, while maintaining mutual synchronization. This unusual nonlinear behavior is explained using coupled Van der Pol equations. A stability analysis provides theoretical limitations on the achievable inter-element phase shift. When the phase of the coupling is zero, the theory predicts an inter-element phase shift that can be varied continuously over the range $-90^\circ < \Delta\theta < +90^\circ$, and is independent of the number of oscillators in the array. An experimental four-element planar MESFET array was built, operating at 10 GHz with close to zero coupling phase, giving a measured phase progression that was continuously variable over the range $-88^\circ < \Delta\theta < 66^\circ$.

I. INTRODUCTION

QUASI-OPTICAL power-combining using arrays of coupled microwave or millimeter-wave oscillators is currently under investigation by many groups [1]–[7]. In this approach, a large number of solid-state oscillator cells are fabricated in a one- or two-dimensional periodic arrangement, where the load of each oscillator is a planar antenna. Mutual coupling between the oscillators—via free-space, transmission-line circuits, or external cavities—enables them to synchronize to a common frequency through the phenomenon of injection-locking [11]–[12]. Much of the research effort to date, including recent theoretical work [8]–[10], has focused primarily on achieving this mutual synchronization. In this paper, we extend the work to encompass phase control and synthesis, leading to a new method for electronic beam scanning.

The principles of beam-scanning in phased-arrays are well known. In a conventional phased-array (Fig. 1(a)), a constant phase progression is established using electronically-controlled phase-shifters at each array element. This approach is conceptually simple, but can be complicated in practice, especially in recent efforts to develop monolithic T/R modules where it is difficult to integrate the phase-shifter circuitry, RF distribution network, control signals and DC bias lines along with the planar antennas. An alternative is the beam-scanning technique described in this paper, depicted in Figure 1b. When the free-running frequencies of the oscillators are within a collective locking-range, the oscillators will spontaneously synchronize with a phase relationship that is controlled by the original

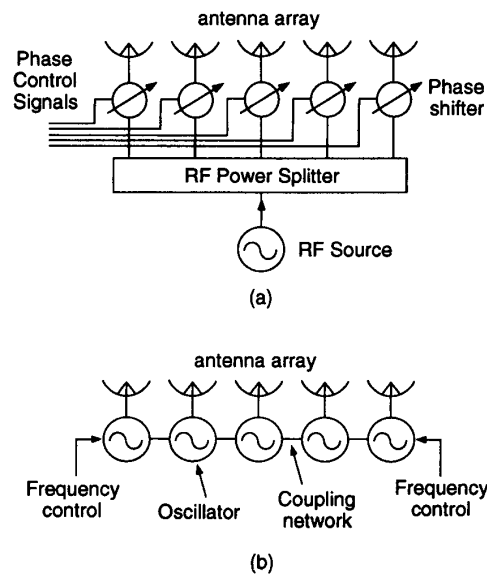

Fig. 1. (a) Block diagram of a conventional phased-array system for beam-scanning, and (b) Illustration of the proposed technique. The dynamics of the injection-locking process establishes a constant phase progression across an array of coupled-oscillators when the end elements are detuned in a particular way.

distribution of free-running frequencies [17]. Furthermore, it will be shown that a constant phase progression is achieved simply by controlling the free-running frequencies of the outermost array elements only. This new approach has the additional advantage of distributing the RF source over a large number of devices, thus eliminating the feed network entirely.

It should be mentioned that the present method bears some resemblance to a previously proposed technique by Stephan [4]–[5], who also used an array of coupled oscillators. In his approach, two signals with a controlled phase difference, $\Delta\varphi$ are injected into the opposite ends of the array. The resulting phase difference between each of the N oscillators is then found to be $\Delta\varphi/(N+1)$. Increasing the number of oscillators in the array decreases the maximum available phase difference between each oscillator, and the scanning range is quite limited for even modest sized arrays. In contrast, the inter-element phase shift obtained with the technique proposed in this paper is independent of the number of oscillators, and can be varied by nearly 180° for a fixed coupling angle.

Manuscript received September 4, 1992; revised February 23, 1993.
The authors are with Department of Electrical Engineering, University of California at Santa Barbara, Santa Barbara, CA 93106.
IEEE Log Number 9211936.

II. COUPLED OSCILLATOR THEORY

A successful theory of coupled oscillators must predict the steady-state phase relationships in the array, and allow for an investigation of stability. This generally requires a dynamic analysis. Our previous work in oscillator arrays for power combining [2], [16], [17] has shown that the arrays can be described adequately by coupled van der Pol equations. In this approach, a single oscillator is modelled by an RLC circuit, with a voltage source to represent injected signals, and a negative resistance to model the device. The circuit equations are reduced to differential equations describing the amplitude and instantaneous phase of the oscillator. The mutual interaction between oscillators is described by a complex coupling coefficient, which for coupling between oscillators i and j is written as $\varepsilon_{ij}e^{j\Phi_{ij}}$. The equations describing the amplitude and phase dynamics for an array of N elements are then given by [17]

$$\frac{dA_i}{dt} = \frac{\omega_i}{2Q} \mu (\alpha_i^2 - A_i^2) A_i + \frac{\omega_i}{2Q} \sum_{j=1}^N \varepsilon_{ij} A_j \cos(\Phi_{ij} + \theta_i - \theta_j) \quad (1a)$$

$$\frac{d\theta_i}{dt} = \omega_i - \frac{\omega_i}{2Q} \sum_{j=1}^N \varepsilon_{ij} \frac{A_j}{A_i} \sin(\Phi_{ij} + \theta_i - \theta_j) \quad (1b)$$

where $i = 1, 2, \dots, N$, and where A_i is the instantaneous amplitude, α_i the free-running amplitude, ω_i is the free-running frequency, and $\theta_i = \omega_i t + \phi_i$ is the instantaneous phase of oscillator i . μ is an empirically determined parameter describing the gain saturation mechanism in the oscillators, and Q is the Q -factor of the oscillator embedding circuits. When $\varepsilon_{ij} = 0$ the oscillators are uncoupled, and (1) reduces to a set of independent sinusoidal oscillators with amplitudes $A_i = \alpha_i$ and frequencies ω_i .

In this general form, each oscillator can be coupled to all other oscillators in the array. However, the arrays discussed in this paper are coupled by weak mutual interactions between the antennas. This coupling occurs predominantly through free-space, with a strength inversely proportional to the element spacing. Because the coupling strength decreases rapidly with distance, elements in the array will interact primarily with adjacent elements. Accordingly, we shall discuss only nearest neighbor coupling, with $\varepsilon_{ij} = 0$ for all $|i - j| \neq 1$. Furthermore, it is assumed that the coupling is reciprocal. If the oscillators in the linear array are equidistant, then all of the coupling terms are identical, and we may make the following simplifications: $\varepsilon_{ij} \Rightarrow \varepsilon$, and $\Phi_{ij} \Rightarrow \Phi$. For loose coupling, as is the case in radiatively coupled arrays, the amplitudes of the oscillators do not change greatly from their free running values in practice, and we can (to first order) disregard the amplitude dynamics. The system is then described by

$$\frac{d\theta_i}{dt} = \omega_i - \frac{\varepsilon\omega_i}{2Q} \sum_{\substack{j=i-1 \\ j \neq i}}^{i+1} \frac{A_j}{A_i} \sin(\Phi + \theta_i - \theta_j) \quad (2)$$

$i = 1, 2, \dots, N$

In practice, there is a maximum frequency difference within which two oscillators will synchronize. For a single oscillator, this locking bandwidth was found by Adler [11] to be

$$\Delta\omega_m = \frac{\omega_i}{2Q} \frac{A_{inj}}{A_i} \quad (3)$$

where A_{inj} and A_i represent the amplitudes of the injected signal and i th oscillator signal respectively. An oscillator can be injection-locked over a frequency range of $\pm\Delta\omega_m$ around its free-running value.

If all of the oscillator frequencies lie within some collective locking bandwidth, then they will eventually synchronize to a common frequency, ω_f , where $d\theta_i/dt = \omega_f$ in the steady-state for all i . This means that the final, steady-state frequency, ω_f , is given by:

$$\omega_f = \omega_i \left[1 - \frac{\varepsilon}{2Q} \sum_{\substack{j=i-1 \\ j \neq i}}^{i+1} \frac{A_j}{A_i} \sin(\Phi + \theta_i - \theta_j) \right] \quad (4)$$

$i = 1, 2, \dots, N$

These N equations allow us to solve for the steady-state phase differences between each oscillator, given the free-running frequencies and coupling parameters. Computer simulations of (2) are usually necessary to compute the stable steady-state phase difference between elements.

III. BEAM-SCANNING IN OSCILLATOR ARRAYS

A. Frequency Distribution

Electronic beam-scanning in antenna arrays requires a constant phase progression along the array, such that $\theta_i - \theta_{i-1} = \Delta\theta$ for all i . Substituting this condition into (4) yields

$$\omega_f = \omega_i \left[1 - \varepsilon' \sum_{\substack{j=i-1 \\ j \neq i}}^{i+1} \frac{A_j}{A_i} \sin(\Phi + \Delta\theta) \right] \quad (5)$$

where the new variable $\varepsilon' = \varepsilon/2Q$ was defined for convenience. For loose coupling or large Q -factors, $\varepsilon' \ll 1$, which we assume in the following analysis. Furthermore, we assume the oscillators have identical amplitudes for simplicity, such that $A_i = 1$. With these assumptions, (5) indicates that a constant phase progression $\Delta\theta$ can be synthesized at a frequency ω_f by the following distribution of free-running frequencies:

$$\omega_i = \begin{cases} \omega_f [1 + \varepsilon' \sin(\Phi + \Delta\theta)] & \text{if } i = 1 \\ \omega_f [1 + 2\varepsilon' \sin \Phi \cos \Delta\theta] & \text{if } 1 < i < N \\ \omega_f [1 + \varepsilon' \sin(\Phi - \Delta\theta)] & \text{if } i = N \end{cases} \quad (6)$$

Note that all of the innermost oscillators share the same frequency. For an array of oscillators with identical free running frequencies, it was previously shown [2], [17] that a broadside pattern ($\Delta\theta = 0^\circ$) is obtained with $\Phi = 0^\circ$, and

an endfire pattern, ($\Delta\theta = 180^\circ$), is obtained when $\Phi = 180^\circ$. For the special case of $\Phi = 0^\circ$, (6) reduces to

$$\omega_i = \begin{cases} \omega_f[1 + \epsilon' \sin \Delta\theta] & \text{if } i = 1 \\ \omega_f & \text{if } 1 < i < N \\ \omega_f[1 - \epsilon' \sin \Delta\theta] & \text{if } i = N \end{cases} \quad (7)$$

and hence the inter-element phase shift is controlled only by the free-running frequency of the end elements. Furthermore, the synchronized frequency is equal to the free-running frequency of the innermost oscillators. Thus by slightly adjusting the free-running frequencies of the end elements in opposite directions by an amount $\epsilon'\omega_f \sin \Delta\theta$, the radiation pattern can be electronically scanned. Interestingly, this influence of end elements on the phase distribution of an oscillator chain was also observed in [8], where the oscillator array was used as a phenomenological model for explaining the spinal locomotion in eels. The resulting constant phase progression was interpreted as a travelling wave on the chain, corresponding to swimming motion.

B. Stability Analysis

There is some ambiguity in (7) regarding the phase shift $\Delta\theta$, which can be resolved by a stability analysis. This procedure will then determine the limits of the scanning range. The stability of nonlinear equations such as (2) can be investigated by a perturbation analysis [2], [17]. Since the relative phase shifts between oscillators is of interest, a dynamic equation for the adjacent phase shifts is derived using (2), giving:

$$\frac{d\Delta\theta_i}{dt} = \omega_i[1 - \epsilon' \sin(\Phi + \Delta\theta_i) - \epsilon' \sin(\Phi - \Delta\theta_{i+1})] - \omega_{i-1}[1 - \epsilon' \sin(\Phi + \Delta\theta_{i-1}) - \epsilon' \sin(\Phi - \Delta\theta_i)]. \quad (8)$$

Assuming a steady-state solution, $\overline{\Delta\theta_i}$, has been computed from (5), we investigate the dynamics of the perturbed solution, $\Delta\theta_i = \overline{\Delta\theta_i} + \delta_i$. The perturbation is small so that $\sin \delta_i \approx \delta_i$, which leads to the following set of linearized equations for the perturbation:

$$\frac{d\delta_i}{dt} = a_i\delta_{i-1} + b_i\delta_i + c_i\delta_{i+1} \quad \text{for } i = 2, 3, \dots, N \quad (9)$$

where

$$\begin{aligned} a_i &= \epsilon'\omega_{i-1} \cos(\Phi + \Delta\theta) \\ b_i &= \epsilon'\omega_i \cos(\Phi + \Delta\theta) - \epsilon'\omega_{i-1} \cos(\Phi - \Delta\theta) \\ c_i &= \epsilon'\omega_i \cos(\Phi - \Delta\theta) \end{aligned}$$

Equation (9) can be placed in matrix form, $d\delta/dt = \mathbf{A}\delta$ where δ is an $N-1$ vector with elements δ_i and \mathbf{A} is the tridiagonal coefficient matrix. Stability requires the perturbation to decay with time, which is satisfied when the eigenvalues of the coefficient matrix have negative real parts. The stability matrix for $\Phi = 0^\circ$ is

$$\mathbf{A} = \epsilon' \cos \Delta\theta \begin{pmatrix} -[\omega_f + \omega_1] & \omega_f & 0 & \dots & 0 \\ \omega_f & -2\omega_f & \omega_f & \dots & 0 \\ 0 & \omega_f & -2\omega_f & \dots & 0 \\ \vdots & \vdots & \vdots & \ddots & \vdots \\ 0 & 0 & 0 & \omega_f & -[\omega_f + \omega_N] \end{pmatrix} \quad (11)$$

which is real, symmetric, and diagonally dominant. The eigenvalues of such a matrix are negative if the matrix is negative-definite [13]. This matrix is negative-definite if all of its diagonal elements are less than zero. Examination of each diagonal element in the stability matrix above reveals that they will be negative if $\cos \Delta\theta > 0$. Therefore the inter-element phase shift is restricted to the range $-90^\circ < \Delta\theta < 90^\circ$ when $\Phi = 0^\circ$. Similar analyses can be carried out for other values of Φ , resulting in a different range of allowable phase-shifts.

The relationship between the successive phase shifts and the scan angle is

$$\Delta\theta = \frac{2\pi d}{\lambda_0} \sin \Psi \quad (12)$$

where Ψ is the scan angle measured from broadside, d is the physical separation between adjacent elements, and λ_0 is the wavelength of interest. Using (6), (9), and (11) allows us to compute the frequency distribution required to synthesize a desired scan angle. The range of scan coverage is determined by the coupling phase and antenna spacing. For example, an array with $d = \lambda_0/2$ has a maximum coverage of $\pm 30^\circ$ from broadside when the coupling phase is zero. A greater scan range can be obtained with smaller antenna spacing. Alternatively, scan coverage can be increased by electronically controlling the coupling phase, but this essentially defeats the purpose of the proposed concept. Note also that we have neglected the issue of scan blindness in planar arrays [14] in this discussion, which will impose additional constraints on the maximum allowable scan coverage.

The angular resolution for this array is set by the stability and accuracy of the Voltage-Controlled Oscillators (VCO's) on the array periphery. Equation (6) indicates that the required tuning range for the VCO's is dependent on the coupling parameter, ϵ' . In the case of extremely weak coupling, $\epsilon' \ll 1$, very small frequency differences can give rise to large phase shifts. In that case, a set of very stable and uniformly similar oscillators would be required, and the modulation bandwidth would be small. Therefore moderately strong coupling is desired, and efforts are currently underway to determine effective techniques for increasing inter-oscillator coupling.

IV. EXPERIMENTAL RESULTS

The theoretical predictions were tested using a four-element, radiatively-coupled active patch array based on the design described in [15] (which was chosen for simplicity). The array (Fig. 2) used 0.787 mm thick Rogers Duroid 5880 substrate with $\epsilon_r = 2.2$, and used NE32184A low-noise GaAs FETs. The width, W , and length, L , of each patch antenna were 4.56 mm and 11.88 mm, respectively. These dimensions

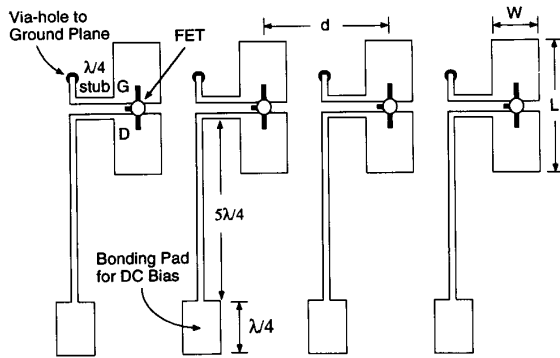

Fig. 2. Diagram illustrating the experimental four element FET array. A simple active patch design using zero gate bias was used [16], with dimensions chosen empirically for operation at 10 GHz. An array spacing of $d = 0.86\lambda_0$ was used to give the desired angle of coupling (see Fig-3).

were chosen empirically so that the oscillator would be bias-tunable over a range of frequencies centered about 10 GHz. The FET source lead was grounded through a via hole in the substrate; in this particular design the frequency and tuning range was very sensitive to the inductance of the source lead. To simplify the biasing, the oscillator was designed to operate at $V_{gs} = 0$, with a DC return path to ground provided by a quarter-wavelength shorted stub, connected to the circuit at a low-impedance point. Drain bias was supplied through a typical bias network consisting of a high impedance $5\lambda/4$ line, followed by a quarter-wavelength impedance bonding pad.

The most critical parameter in the design of this array was the oscillator separation, which determines both the coupling strength and the coupling phase as well as the scanning range. An imaging technique [16] was used to characterize the coupling parameters as follows: a single active patch was tuned to a free-running frequency of 10 GHz; the patch antenna was then positioned near a vertical ground plane so that its surface current flowed parallel to the ground plane, thus simulating two identical, out-of-phase, coupled oscillators; as the position of the patch antenna was varied, a frequency shift is observed which can be related to the coupling parameters [16]. The results are shown in Fig. 3, and indicate that a center-to-center spacing of $d = 0.86\lambda_0$ was required to obtain $\Phi = 0^\circ$. This limits the theoretical maximum scan coverage to $\pm 17^\circ$ for this array.

The individual bias to each element allowed us to establish the free-running frequencies prescribed in (7) for a given scan angle through bias tuning. Several array patterns were measured for various frequency distributions, and some of the results are shown in Fig. 4–5. It was possible to continuously scan the radiation pattern from -15° to $+12.5^\circ$ by adjusting the end-element frequencies only. This compares favorably with the predicted scan range of $\pm 17^\circ$, and corresponds to an inter-element phase-shift range of $-80^\circ < \Delta\theta < 66^\circ$. Figure 4a shows the measured broadside patterns, obtained by setting all the oscillators' natural frequencies to 10.000 GHz. When the pattern was scanned to -15° (figure 4c), the frequencies of the end elements were 10.0075 GHz and 9.9925 GHz. Figure 4b shows an interme-

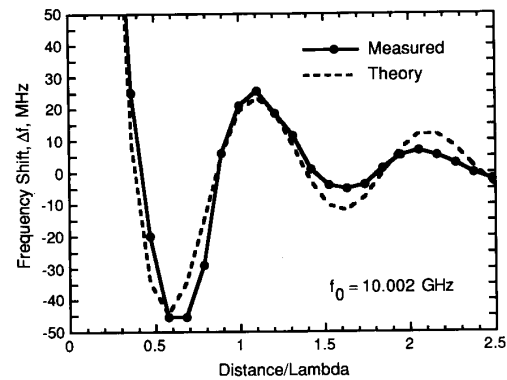

Fig. 3. Measured output frequency of a two-oscillator system (single oscillator imaged by a vertical ground plane) versus antenna separation. Using a simple first order model described in [16], this frequency shift can be related to the coupling parameters with good correlation between theory and measurement.

diate case. In the case of $+12.5^\circ$ scan angle (Fig. 5), the frequencies of the end elements in the array were 9.985 GHz and 10.015 GHz, respectively.

The slight asymmetry in the results suggest at least two things: that the inter-element coupling phase was not exactly zero as intended, and that the oscillators are not modelled exactly by the Van der Pol equation. A simple experiment using two of the array elements was then conducted to determine the actual coupling phase. When the two oscillators were each tuned to the same free-running frequency of 10 GHz, the measured radiation pattern was clearly broadside but a steady-state output frequency of 9.9408 GHz was observed. This frequency shift indicates that the coupling phase, Φ , was not zero as desired. This discrepancy is probably a result of mutual coupling through the substrate (surface waves) which was not faithfully reproduced by the imaging method of [16]. Additional fitting to the measurements indicated that the coupling phase, Φ , was approximately 18° , and the coupling parameter, e' , was 0.008. The theoretical radiation patterns shown in Fig. 4 were then computed by substituting these coupling parameters into (5), solving for the predicted phase shifts, and multiplying the theoretical array factor with the measured pattern of a single patch. The figures indicate very good agreement between the measurement and theory.

V. CONCLUSIONS

A new technique for electronic beam scanning has been presented that eliminates the need for phase shifters. This technique and its limitations can be explored using coupled-oscillator theory, and was tested in simple fashion using a 4×1 linear array of active patch antennas. By adjusting the frequencies of the end oscillators in the chain, the radiation pattern could be continuously steered over a range of angles from -15° to $+12.5^\circ$. The measured scan range is actually very close to the theoretical limit for this particular array, due to the abnormally large antenna spacing that was used. Some small discrepancies were observed between the theory and experiment as a result of nonuniform oscillator amplitudes, the

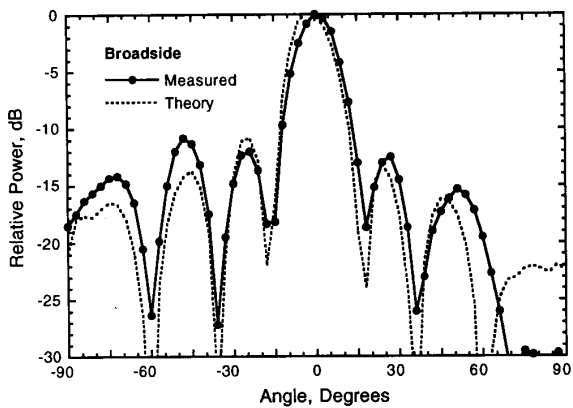

(a)

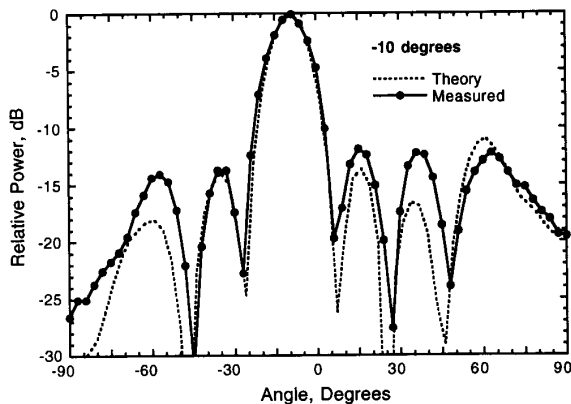

(b)

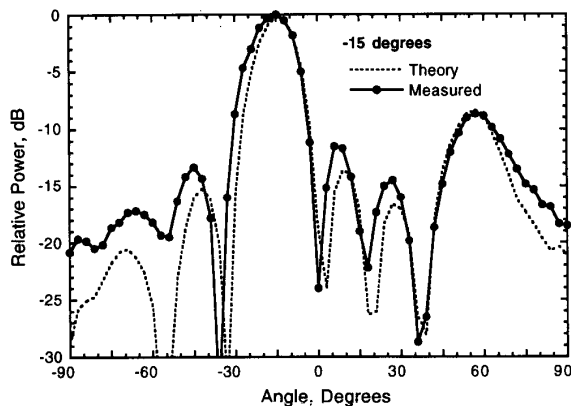

(c)

Fig. 4. Correlation between theory and experiment for three different scan angles. (a) Measured and theoretical broadside patterns, obtained when all oscillators have identical frequencies. Measured and theoretical patterns for (b) -10° and (c) -15° similarly show good agreement.

simplicity of the modelling, and incorrect coupling parameters, but overall the results are encouraging. Indeed, the fact that our crude array worked at all suggests that the concept is

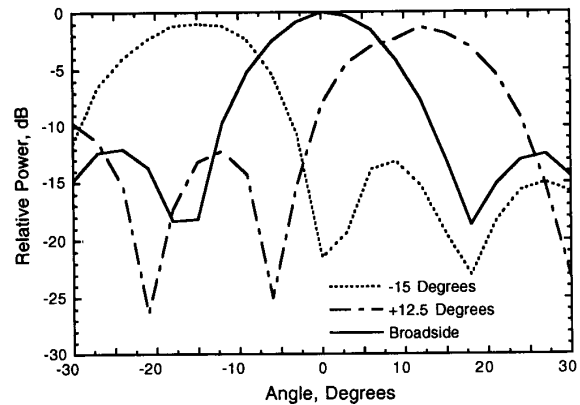

Fig. 5. Comparison of measured radiation patterns at three different scan angles. Continuous beam scanning was possible from -15° to $+12.5^\circ$ by adjusting the end-element frequencies, which is close to the maximum $\pm 17^\circ$ predicted by the theory. The scan range was limited by the large antenna spacing.

fairly robust, and that extremely tight tolerances would not be required in a practical array.

This new method could be very useful in future monolithic millimeter-wave phased-array modules, where substrate space is scarce, and should be much easier to calibrate than conventional phased arrays since only two control signals are used. For use in a practical system, other features of the array remain to be studied. These include the scanning speed of the array, and the modulation bandwidth. It is likely that there is an important scan range/bandwidth tradeoff in this approach. The effects of randomness in the frequency distribution is another important issue, since it will of course be impossible to fabricate a large array of oscillators with identical free-running frequencies. Another interesting concept to investigate is the effects of amplitude tapering on the operation of the array, which would be important in low-sidelobe applications. Methods for increasing the coupling strength would also be beneficial, since this would permit more coarse frequency control. The concept should also be explored for two dimensional arrays, for possible scanning in azimuth and elevation.

ACKNOWLEDGMENT

The authors would like to thank Prof. Rick Compton at Cornell and Prof. Dave Rutledge at CalTech for their support and encouragement. Thanks also go out to California Eastern Labs, NEC, and the Rogers Corp. for generously donating the GaAs FETs and microwave substrates used in this work.

REFERENCES

- [1] J. W. Mink, "Quasi-optical power-combining of solid-state millimeter-wave sources," *IEEE Trans. Microwave Theory Tech.*, vol. MTT-34, pp. 273-279, Feb. 1986.
- [2] R. A. York and R. C. Compton, "Quasi-optical power-combining using mutually synchronized oscillator arrays," *IEEE Trans. Microwave Theory Tech.*, vol. 39, pp. 1000-1009, June 1991.
- [3] D. B. Rutledge, Z. B. Popovic, R. M. Weikle, M. Kim, K. A. Potter, R. A. York, and R. C. Compton, "Quasi-optical power combining arrays,"

- Invited Paper, *IEEE MTT-S International Microwave Symp. Dig.*, Dallas, May 1990.
- [4] K. D. Stephan, "Inter-injection locked oscillators for power combining and phased arrays," *IEEE Trans. Microwave Theory Tech.*, vol. MTT-34, pp. 1017-1025, Oct. 1986.
- [5] K. D. Stephan and W. A. Morgan, "Analysis of inter-injection-locked oscillators for Integrated phased arrays," *IEEE Trans. Antennas Propagat.*, vol. AP-35, pp. 771-781, July 1987.
- [6] K. Chang, K. A. Hummer, and J. L. Klein, "Experiments on injection-locking of active antenna elements for active phased arrays and spatial power combiners," *IEEE Trans. Microwave Theory Tech.*, vol. 37, pp. 1078-1084, July 1989.
- [7] J. Birkeland and T. Itoh, "A 16 element quasi-optical FET oscillator power combining array with external injection locking," *IEEE Trans. Microwave Theory Tech.*, vol. 40, pp. 475-481, Mar. 1992.
- [8] A. H. Cohen, P. J. Holmes, and R. H. Rand, "The nature of the coupling between segmental oscillators of the Lamprey spinal generator for locomotion: A mathematical model," *J. Math. Bio.*, vol. 13, pp. 345-369, 1982.
- [9] S. H. Strogatz and R. E. Mirollo, "Phase-locking and critical phenomena in lattices of coupled nonlinear oscillators with random intrinsic frequencies," *Physica D*, vol. 31, pp. 143-168, 1988.
- [10] R. H. Rand, A. H. Cohen, and P. J. Holmes, "Systems of coupled oscillators as models of central pattern generators," Ch. 9, *Neural Control of Rhythmic Movements in Vertebrates*, A. H. Cohen, Ed., New York: Wiley, 1988.
- [11] R. Adler, "A study of locking phenomena in oscillators," *Proc IRE*, vol. 34, pp. 351-357, June 1946; also reprinted in *Proc. IEEE*, vol. 61, pp. 1380-1385, Oct. 1973.
- [12] K. Kurokawa, "Injection-locking of solid state microwave oscillators," *Proc. IEEE*, vol. 61, pp. 1386-1409, Oct. 1973.
- [13] G. Strang, *Linear Algebra and Its Applications*. San Diego: Harcourt Brace Jovanovich 1988, pp. 330-331.
- [14] D. M. Pozar and D. H. Schaubert, "Comparison of architectures for monolithic phased array antennas," *Microwave J.*, pp. 93-104, Mar. 1986.
- [15] R. A. York, R. M. Martinez, and R. C. Compton, "Hybrid transistor and patch antenna element for array applications," *Electron. Lett.*, vol. 26, pp. 494-495, Mar. 1990.
- [16] R. A. York and R. C. Compton, "Measurement and modelling of radiative coupling in oscillator arrays," to appear in *IEEE Trans. Microwave Theory Tech.*
- [17] R. A. York, "Nonlinear analysis of phase relationships in quasi-optical oscillator arrays," this issue of *IEEE Trans. Microwave Theory Tech.*

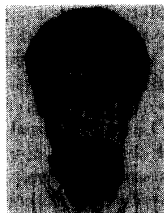

Peter Liao (S'92) received his B.S. degree in electrical engineering from The Cooper Union in 1989, and the M.S. degree in electrical engineering from the University of California at Santa Barbara in 1991, where he is currently pursuing the Ph.D. degree. His current research interests include quasi-optical power combining arrays, microwave oscillator and circuit design, and coupled oscillator theory.

R. A. York (S'86-M'91) for photograph and biography, see this issue, p. 1809.